

I

Le **GS.40** sono elettropompe robuste ed affidabili, adatte per acque sporche, acque reflue civili ed industriali.

APPLICAZIONE: l'elettropompa deve funzionare completamente immersa per garantire il raffreddamento da parte del liquido circostante. Sono idonee al pompaggio di acque derivate da reflui civili / industriali contenenti fibre lunghe e liquidi con PH compreso tra 6 e 11.

TRATTAMENTO EPOX: su richiesta possiamo fornire l'elettropompa con uno speciale trattamento superficiale costituito da una resina bicomponente avente elevata resistenza all'abrasione e agli agenti acidi.

SISTEMA IDRAULICO CON TRITURATORE:

Le pompe della serie GS sono equipaggiate di un coltello rotante e di un sistema tagliante fisso in grado di sminuzzare e strappare fibre tessili che possono essere presenti nelle acque di rifiuto. L'utilizzo di tali pompe viene consigliato ove la tubazione di mandata è di dimensione ridotta (da 32mm a 50mm) e per sistemi fognari in pressione.

F

Les **GS40** sont robustes et fiables pompes, adaptés pour l'eau sale et des eaux usées civiles et industrielles.

APPLICATION: la pompe doit fonctionner complètement immergé pour assurer le refroidissement par le liquide environnant. Ils conviennent pour le pompage de l'eau provenant des eaux usées civile / industrielle contenant des fibres longues et liquide avec PH entre 6 et 11.

TRAITEMENT EPOX: sur demande nous pouvons fournir la pompe avec un traitement de surface spécial est constitué d'une résine à deux composants présentant une résistance élevée à l'abrasion et à l'acide agents.

SYSTEME HYDRAULIQUE AVEC DILACELATRICE:

Les pompes de la série GS sont équipés d'un couteau rotatif et d'un système de coupe fixe capable de déchiquetage et de déchirure des fibres textiles qui peuvent être présents dans les eaux usées. L'utilisation de ces pompes est recommandée lorsque le tuyau de refoulement est de petite taille (de 32mm à 50mm) et pour les systèmes d'égout sous pression.

G

The **GS.40** are robust and reliable pumps, suitable for dirty water, civil and industrial waste waters.

APPLICATION: the pump must operate completely submerged to ensure the motor cooling by the surrounded liquid. They are suitable to pump liquids from civil / industrial wastewater containing long fibers and with PH between 6 and 11.

EPOX TREATMENT: on request we can supply the pump with a special surface coating consisting of a two-component resin having high resistance to abrasion and acid agents.

HYDRAULIC SYSTEM WITH SHREDDER:

The GS series are pumps equipped with a rotating knife and a fixed cutting system capable of shredding and tearing textile fibers that can be in waste waters. These pumps are recommended where the delivery pipe has small size (from 32mm up to 50mm) and for sewer systems under pressure.

E

Las **GS40** son bombas robustos y fiables, apto para agua sucia y las aguas residuales civiles e industriales.

APLICACIÓN: la bomba eléctrica debe operar sumergido completamente para garantizar una refrigeración por líquido circundante. Son adecuados para el bombeo de agua en el derivado de aguas residuales civiles / industriales que contienen fibras largas y líquido con pH entre 6 y 11.

TRATAMIENTO EPOX: A petición se puede suministrar la bomba eléctrica con un tratamiento especial de la superficie consiste en una resina de dos componentes que tiene una alta resistencia a la abrasión y agentes ácidos.

SISTEMA HIDRÁULICO CON TRITURADOR:

Las bombas de la serie GS están equipadas con una cuchilla giratoria y un sistema de corte fijo capaz de triturar y desgarrar las fibras textiles que pueden estar presentes en las aguas residuales. Se recomienda el uso de este tipo de bombas en el que el tubo de suministro es de pequeño tamaño (de 32 mm a 50 mm) y para los sistemas de alcantarillado bajo presión.



ELETTROPOMPE SERIE GS - GRINDER

PUMPS TYPE GS - GRINDER



CURVE DEI PRODOTTI - CURVES OF PRODUCTS -

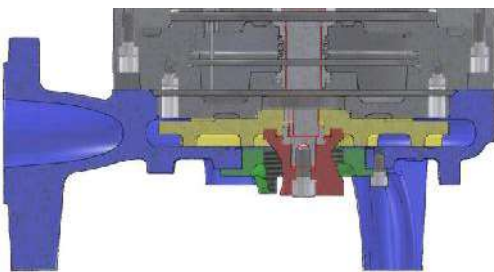
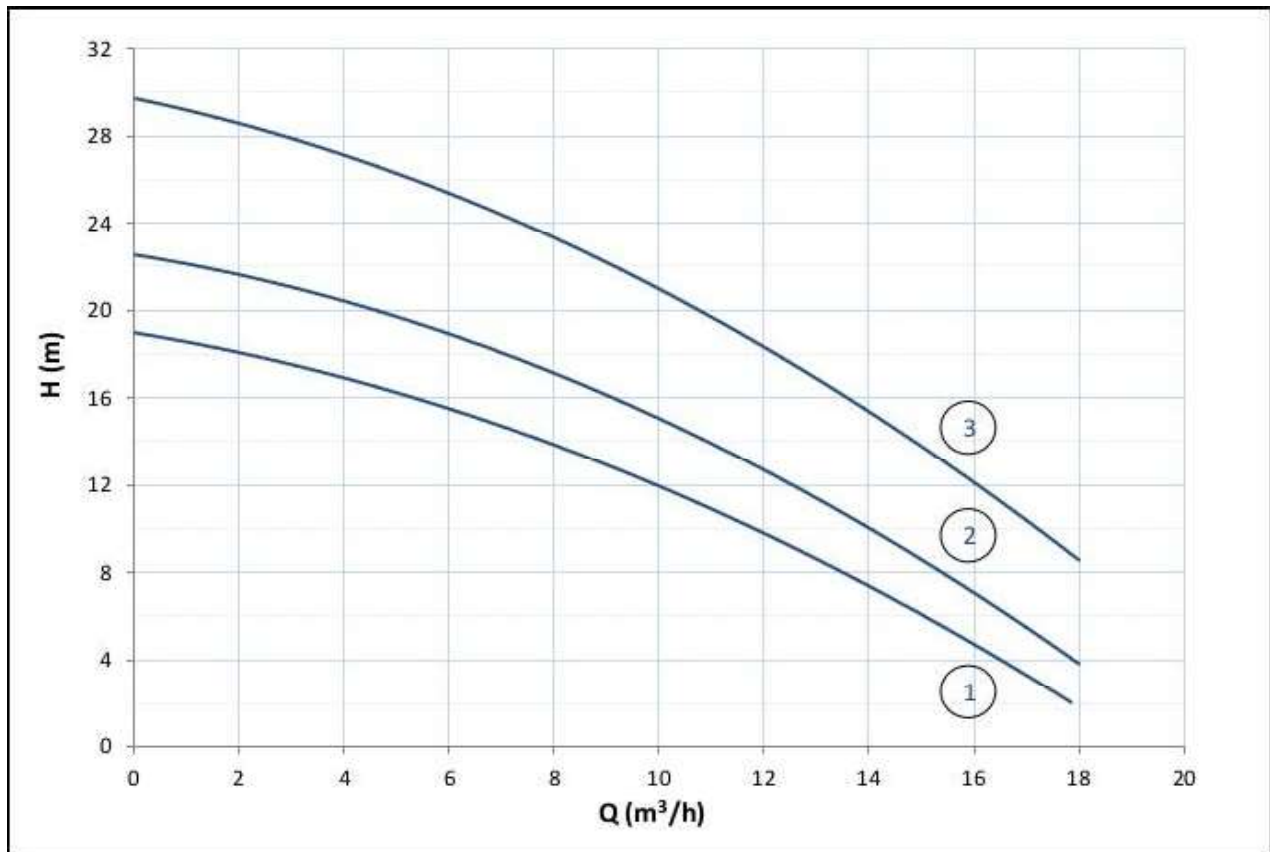

Elettropompe sommergibili caratterizzate da una girante aperta e dotata di un sistema per sminuzzare e tritare fibre. Questa soluzione idraulica definisce piccoli passaggi liberi di corpi solidi e un buon rendimento della pompa. Soluzione indicata per il pompaggio di acque luride e reflui civili ed industriali contenenti fibre lunghe.

Submersible pumps characterized by an open impeller and equipped with a system for shredding and grind fibers that can be found inside of the sewage. This hydraulic solution defines small free passage of solids and a good pump performance. This is a solution suitable to pump sewage and domestic/industrial waste waters containing long fibers.

	Ref.	Type	kW	Poles	Free passage	Kg
DN 40	1	GS.40.11.2	1,1	2	-	39
	2	GS.40.15.2	1,5	2		40
	3	GS.40.22.2	1,8	2		41

Caratteristiche costruttive - construction features

Corpo motore e corpo pompa:	Ghisa	EN GJLI-250
Motor body and pump housing:	Cast Iron	
Groupe motor et corps de la pompe:	Fer de fonte	
Unidad de motor y cuerpo hydraulico:	Hierro fundido	

Albero motore:	Acciaio
Motor shaft:	Steel - Acier
Arbre moteur:	Acero:
Eje del motor:	AISI 420

Anello tenuta radiale e bussola protezione albero:	NBR + AISI 316
Radial seal and shaft protection sleeve:	
Garniture radial et douille de protection d'arbre:	
Corteco y manga de protección del eje:	

Tenuta meccanica:	Carb.silicium
Mechanical seal:	-
Garniture mécanique:	Carb.silicium
Sello mecánico:	

Anello tenuta radiale:	NBR
Radial seal:	
Garniture radial:	
Corteco:	

Sistema di triturazione:	AISI 440C
Grinder system:	
Dilacelatrice:	
Triturador:	

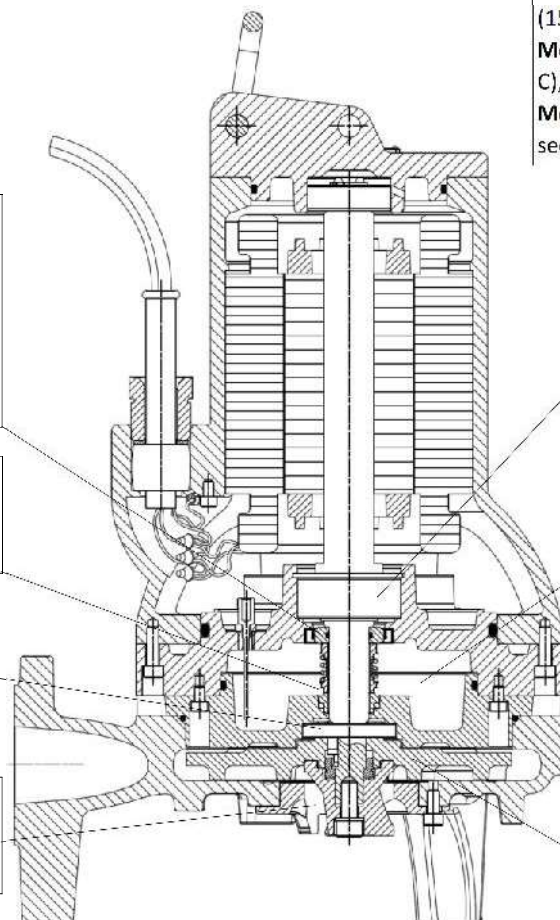

Motore asincrono in classe di isolamento F (155°C), a secco e raffreddato dal liquido circostante;
Asynchronous dry motor, insulation class F (155 ° C), cooled by the surrounding liquid;
Moteur asynchrone, classe d'isolation F (155 ° C), sec et refroidi par le liquide environnant;
Motor asíncrono, aislamiento clase F (155 ° C), seco y refrigerado por el líquido que rodea.

Cuscinetti sovradimensionati;
Heavy-duty bearings;
Robustes roulements;
Cojinetes de servicio pesado.

Camera olio per il raffreddamento e la lubrificazione delle tenute meccaniche;

Oil chamber for cooling and lubrication of mechanical seals;

Chambre d'huile pour le refroidissement et la lubrification des garnitures mécaniques;

Cámara de aceite para la refrigeración y la lubricación de los sellos mecánicos.

Girante semi-aperta:	EN GJL 250
Open impeller:	
Roue ouverte:	
Impulsor abierto:	

Dimensioni d'ingombro - overall dimensions

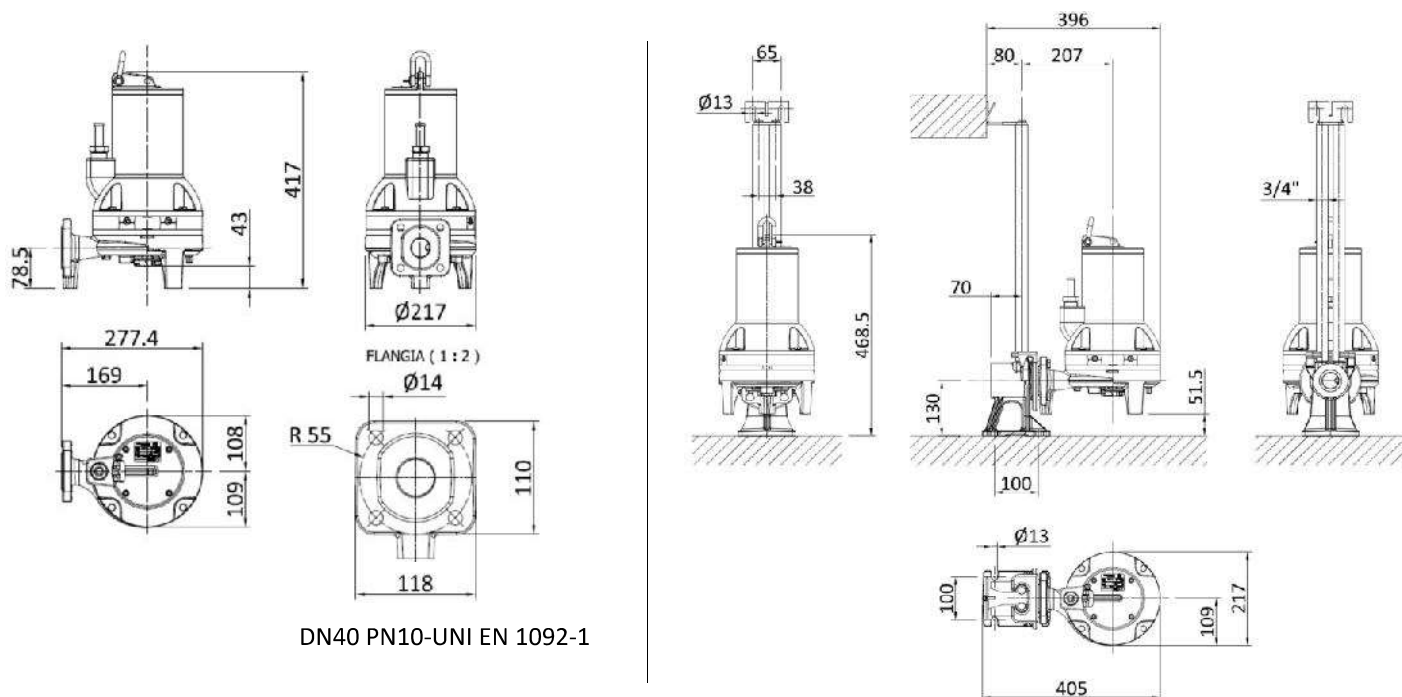

DN40 PN10-UNI EN 1092-1

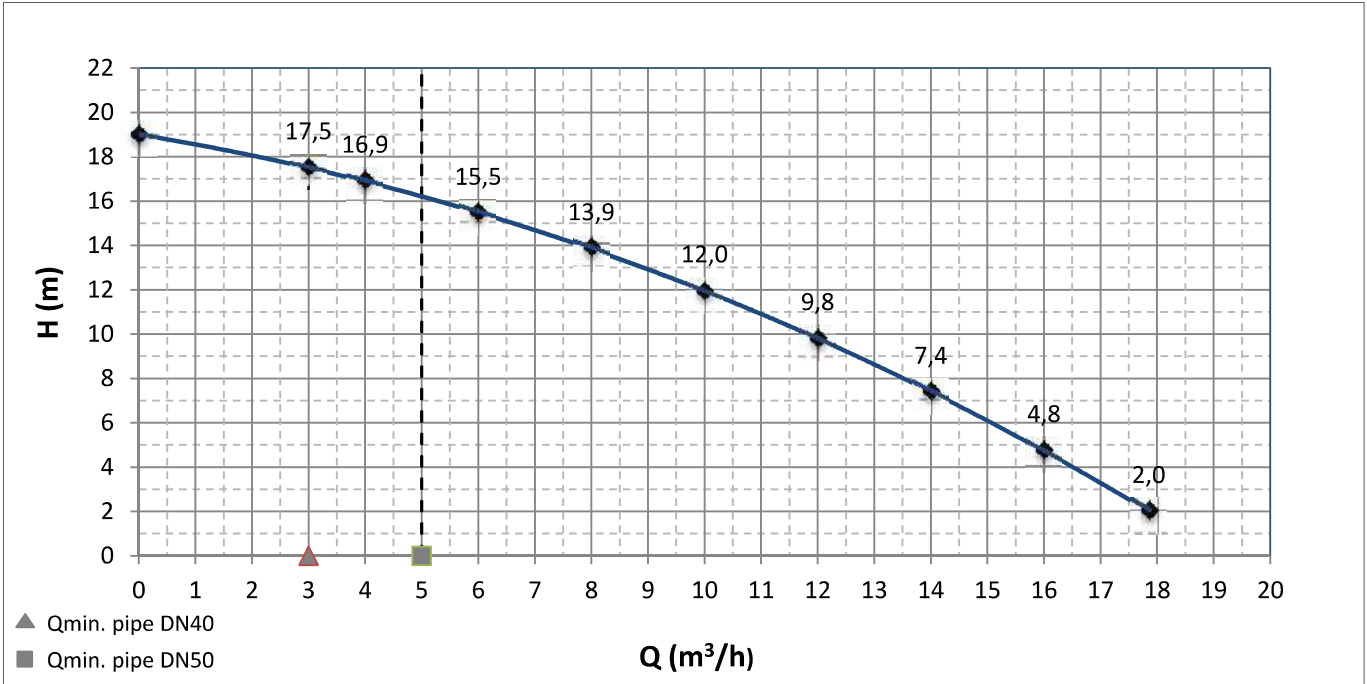

PORTATA - FLOW - DEBIT - FLUJO

l/min	0,0	50,0	66,7	100,0	133,3	166,7	200,0	233,3	266,7	297,5
l/sec	0,0	0,8	1,1	1,7	2,2	2,8	3,3	3,9	4,4	5,0
m³/h	0,0	3,0	4,0	6,0	8,0	10,0	12,0	14,0	16,0	17,9

PREVALENZA - HEAD - HAUTEUR - ALTURA

m	19,0	17,5	16,9	15,5	13,9	12,0	9,8	7,4	4,8	2,0
---	------	------	------	------	------	------	-----	-----	-----	-----

DATI TECNICI - TECHNICAL DATAS - CARACTERISTIQUES TECHNIQUES - DATOS TECNICOS

Tensione nominale Nominal voltage Tension nominal Tensiòn nominal	1~ 230 V 50 Hz	Corrente di spunto Starting current Courant de démarrage Corriente de arranque	24,0 A	Mandata della pompa Discharge of the pump Refolement du pompe Descarga de la bomba	DN 40
Pot. max. assorbita dalla rete P1 Max.abs.power from main P1 Max. puissance de la reseau P1 Potencia max. de la red P1	1,5 kW	Corrente max. assorbita Max absorbed current Consommation maximale Corriente max. de consumo	8,0 A	Rendimento idraulico massimo Max. hydraulic efficiency Max. rendement hydraulique Maxima eficiencia hidràulica	30%
Potenza all'albero P2 Shaft power P2 Max. d'energie hydraulique P2 Max. potencia hidràulica P2	1,1 kW	Condensatore Capacitor Condensaterur Condensadorconsumo	140+40 µF	Temperatura massima del liquido Pumped liquid max temperature Température maximale du liquide Temperatura maxima del liquido	35°C
Avviamento Starting Début Arranque	D.O.L.	Fattore di potenza Power factor Facteur de puissance Factor de potencia	cos φ 0,9	Numero massimo di avviamenti/ora Max. startings per hour Nombre max. de démarrages/heure Nr. Max comienzo/h	25
Tolleranze secondo UNI EN ISO 9906 annex A Le curve si riferiscono a liquidi con densità di 1 kg/dm3 e viscosità pari a quella dell'acqua in condizioni standard Curves established for liquids with density 1kg/dm3 and same viscosity than water				Peso Weight Poids Peso	39 kg

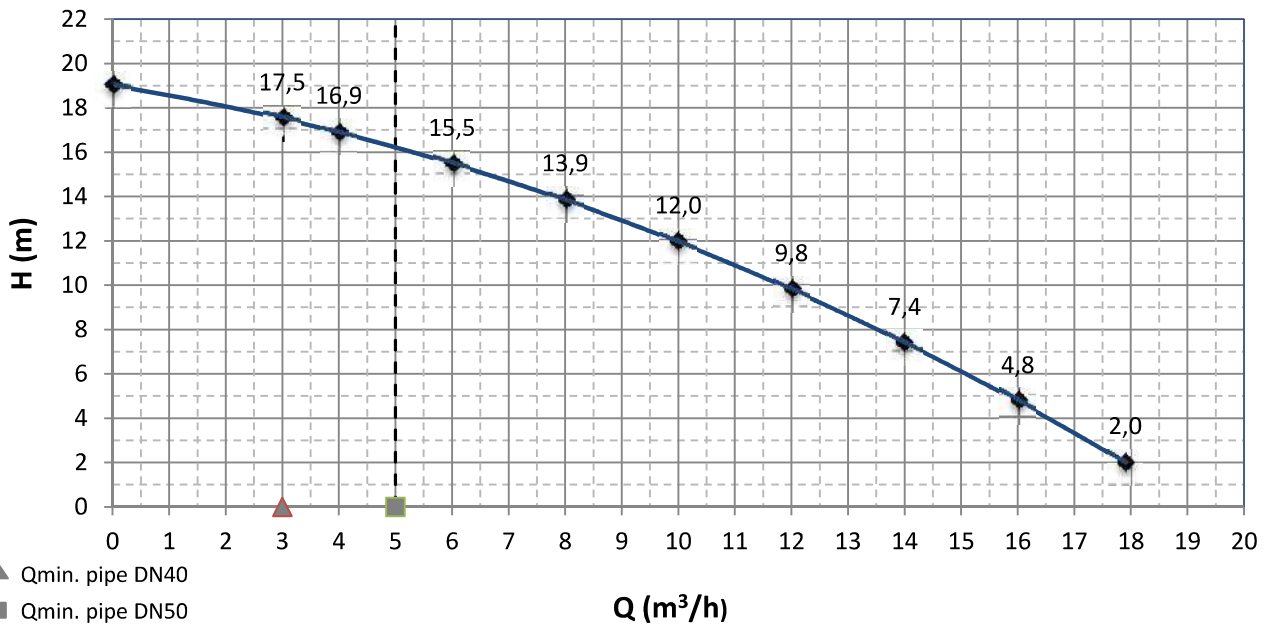

PORTATA - FLOW - DEBIT - FLUJO

l/min	0,0	50,0	66,7	100,0	133,3	166,7	200,0	233,3	266,7	298,3
l/sec	0,0	0,8	1,1	1,7	2,2	2,8	3,3	3,9	4,4	5,0
m³/h	0,0	3,0	4,0	6,0	8,0	10,0	12,0	14,0	16,0	17,9

PREVALENZA - HEAD - HAUTEUR - ALTURA

m	19,0	17,5	16,9	15,5	13,9	12,0	9,8	7,4	4,8	2,0
---	------	------	------	------	------	------	-----	-----	-----	-----

DATI TECNICI - TECHNICAL DATAS - CARACTERISTIQUES TECHNIQUES - DATOS TECNICOS

Tensione nominale Nominal voltage Tension nominal Tensiòn nominal	3 ~ 400 V 50 Hz	Corrente di spunto Starting current Courant de démarrage Corriente de arranque	15,7 A	Mandata della pompa Discharge of the pump Refolement du pompe Descarga de la bomba	DN 40
Pot. max. assorbita dalla rete P1 Max.abs.power from main P1 Max. puissance de la reseau P1 Potencia max. de la red P1	1,5 kW	Corrente max. assorbita Max absorbed current Consommation maximale Corriente max. de consumo	3,0 A	Rendimento idraulico massimo Max. hydraulic efficiency Max. rendement hydraulique Maxima eficiencia hidràulica	30%
Potenza all'albero P2 Shaft power P2 Max. d'energie hydraulique P2 Max. potencia hidràulica P2	1,1 kW	Condensatore Capacitor Condensaterur Condensadorconsumo	- µF	Temperatura massima del liquido Pumped liquid max temperature Température maximale du liquide Temperatura maxima del liquido	40°C
Avviamento Starting Début Arranque	D.O.L.	Fattore di potenza Power factor Facteur de puissance Factor de potencia	cos φ 0,81	Numero massimo di avviamenti/ora Max. startings per hour Nombre max. de démarrages/heure Nr. Max comienzo/h	25
Tolleranze secondo UNI EN ISO 9906 annex A Le curve si riferiscono a liquidi con densità di 1 kg/dm ³ e viscosità pari a quella dell'acqua in condizioni standard Curves established for liquids with density 1kg/dm ³ and same viscosity than water				Peso Weight Poids Peso	39 kg

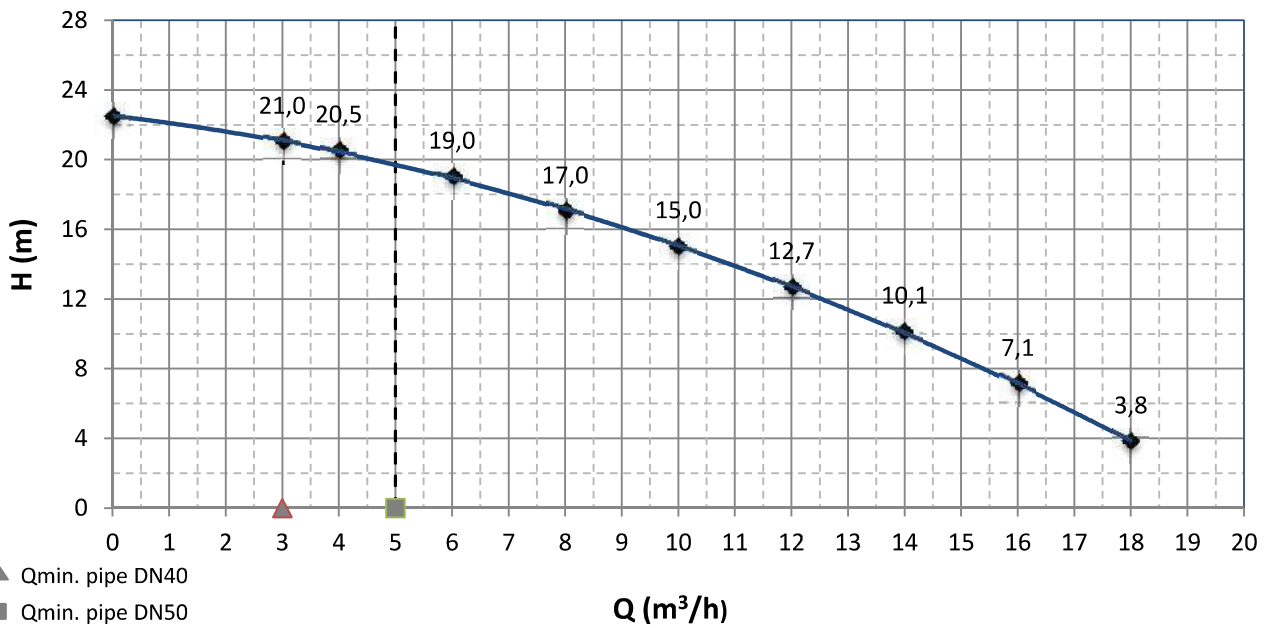

PORTATA - FLOW - DEBIT - FLUJO

l/min	0,0	50,0	66,7	100,0	133,3	166,7	200,0	233,3	266,7	300,0
l/sec	0,0	0,8	1,1	1,7	2,2	2,8	3,3	3,9	4,4	5,0
m³/h	0,0	3,0	4,0	6,0	8,0	10,0	12,0	14,0	16,0	18,0

PREVALENZA - HEAD - HAUTEUR - ALTURA

m	22,5	21,0	20,5	19,0	17,0	15,0	12,7	10,1	7,1	3,8
---	------	------	------	------	------	------	------	------	-----	-----

DATI TECNICI - TECHNICAL DATAS - CARACTERISTIQUES TECHNIQUES - DATOS TECNICOS

Tensione nominale Nominal voltage Tension nominal Tensiòn nominal	1 ~ 230 V 50 Hz	Corrente di spunto Starting current Courant de démarrage Corriente de arranque	30,0 A	Mandata della pompa Discharge of the pump Refolement du pompe Descarga de la bomba	DN 40
Pot. max. assorbita dalla rete P1 Max.abs.power from main P1 Max. puissance de la reseau P1 Potencia max. de la red P1	2,0 kW	Corrente max. assorbita Max absorbed current Consommation maximale Corriente max. de consumo	10 A	Rendimento idraulico massimo Max. hydraulic efficiency Max. rendement hydraulique Maxima eficiencia hidràulica	32%
Potenza all'albero P2 Shaft power P2 Max. d'energie hydraulique P2 Max. potencia hidràulica P2	1,5 kW	Condensatore Capacitor Condensaterur Condensadorconsumo	140+40 µf	Temperatura massima del liquido Pumped liquid max temperature Température maximale du liquide Temperatura maxima del liquido	40°C
Avviamento Starting Début Arranque	D.O.L.	Fattore di potenza Power factor Facteur de puissance Factor de potencia	cos φ 0,92	Numero massimo di avviamenti/ora Max. startings per hour Nombre max. de démarrages/heure Nr. Max comienzo/h	25
Tolleranze secondo UNI EN ISO 9906 annex A Le curve si riferiscono a liquidi con densità di 1 kg/dm3 e viscosità pari a quella dell'acqua in condizioni standard Curves established for liquids with density 1kg/dm3 and same viscosity than water				Peso Weight Poids Peso	40 kg

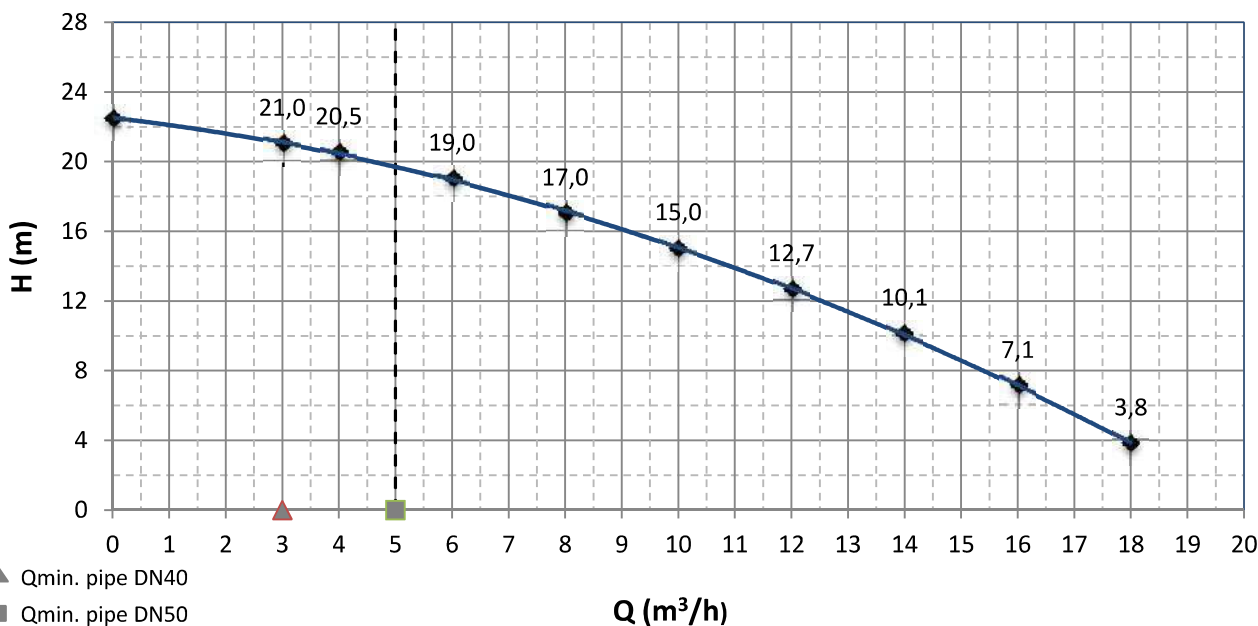

PORTATA - FLOW - DEBIT - FLUJO

l/min	0,0	50,0	66,7	100,0	133,3	166,7	200,0	233,3	266,7	300,0
l/sec	0,0	0,8	1,1	1,7	2,2	2,8	3,3	3,9	4,4	5,0
m³/h	0,0	3,0	4,0	6,0	8,0	10,0	12,0	14,0	16,0	18,0

PREVALENZA - HEAD - HAUTEUR - ALTURA

m	22,5	21,0	20,5	19,0	17,0	15,0	12,7	10,1	7,1	3,8
---	------	------	------	------	------	------	------	------	-----	-----

DATI TECNICI - TECHNICAL DATAS - CARACTERISTIQUES TECHNIQUES - DATOS TECNICOS

Tensione nominale Nominal voltage Tension nominal Tensiòn nominal	3 ~ 400 V 50 Hz	Corrente di spunto Starting current Courant de démarrage Corriente de arranque	22,0 A	Mandata della pompa Discharge of the pump Refolement du pompe Descarga de la bomba	DN 40
Pot. max. assorbita dalla rete P1 Max.abs.power from main P1 Max. puissance de la reseau P1 Potencia max. de la red P1	2,0 kW	Corrente max. assorbita Max absorbed current Consommation maximale Corriente max. de consumo	4,1 A	Rendimento idraulico massimo Max. hydraulic efficiency Max. rendement hydraulique Maxima eficiencia hidràulica	32%
Potenza all'albero P2 Shaft power P2 Max. d'energie hydraulique P2 Max. potencia hidràulica P2	1,5 kW	Condensatore Capacitor Condensaterur Condensadorconsumo	- µF	Temperatura massima del liquido Pumped liquid max temperature Température maximale du liquide Temperatura maxima del liquido	40°C
Avviamento Starting Début Arranque	D.O.L.	Fattore di potenza Power factor Facteur de puissance Factor de potencia	cos φ 0,88	Numero massimo di avviamenti/ora Max. startings per hour Nombre max. de démarrages/heure Nr. Max comienzo/h	25
Tolleranze secondo UNI EN ISO 9906 annex A Le curve si riferiscono a liquidi con densità di 1 kg/dm3 e viscosità pari a quella dell'acqua in condizioni standard Curves established for liquids with density 1kg/dm3 and same viscosity than water				Peso Weight Poids Peso	40 kg

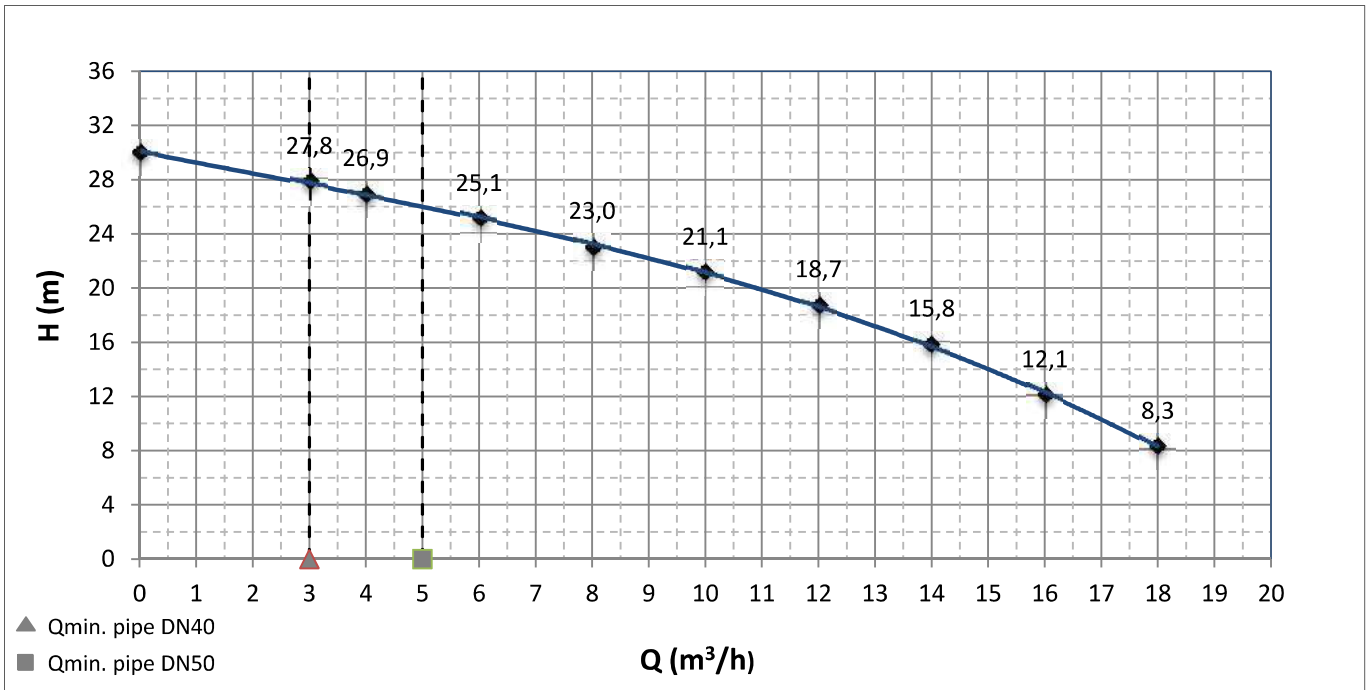

PORTATA - FLOW - DEBIT - FLUJO

l/min	0,0	50,0	66,7	100,0	133,3	166,7	200,0	233,3	266,7	300,0
l/sec	0,0	0,8	1,1	1,7	2,2	2,8	3,3	3,9	4,4	5,0
m³/h	0,0	3,0	4,0	6,0	8,0	10,0	12,0	14,0	16,0	18,0

PREVALENZA - HEAD - HAUTEUR - ALTURA

m	30,0	27,8	26,9	25,1	23,0	21,1	18,7	15,8	12,1	8,3
---	------	------	------	------	------	------	------	------	------	-----

DATI TECNICI - TECHNICAL DATAS - CARACTERISTIQUES TECHNIQUES - DATOS TECNICOS

Tensione nominale Nominal voltage Tension nominal Tensiòn nominal	3 ~ 400 V 50 Hz	Corrente di spunto Starting current Courant de démarrage Corriente de arranque	33,0 A	Mandata della pompa Discharge of the pump Refoulement du pompe Descarga de la bomba	DN 40
Pot. max. assorbita dalla rete P1 Max.abs.power from main P1 Max. puissance de la reseau P1 Potencia max. de la red P1	3,0 kW	Corrente max. assorbita Max absorbed current Consommation maximale Corriente max. de consumo	5,4 A	Rendimento idraulico massimo Max. hydraulic efficiency Max. rendement hydraulique Maxima eficiencia hidràulica	32%
Potenza all'albero P2 Shaft power P2 Max. d'energie hydraulique P2 Max. potencia hidràulica P2	2,2 kW	Condensatore Capacitor Condensaterur Condensadorconsumo	- µF	Temperatura massima del liquido Pumped liquid max temperature Température maximale du liquide Temperatura maxima del liquido	40°C
Avviamento Starting Début Arranque	D.O.L.	Fattore di potenza Power factor Facteur de puissance Factor de potencia	cos φ 0,88	Numero massimo di avviamenti/ora Max. startings per hour Nombre max. de démarrages/heure Nr. Max comienzo/h	25
Tolleranze secondo UNI EN ISO 9906 annex A Le curve si riferiscono a liquidi con densità di 1 kg/dm3 e viscosità pari a quella dell'acqua in condizioni standard Curves established for liquids with density 1kg/dm3 and same viscosity than water				Peso Weight Poids Peso	41 kg